

LPM-150

1½" LP-Gas Flowmeter

Product Bulletin

Designed for bobtail tank trucks and high-flow dispensing applications, the LPM-150 offers the widest flow range (12 - 60 gpm) available in a 1½" positive displacement meter. The LPM-150 utilizes a durable, all-ductile-iron housing for reliability, durability and years of low-maintenance use. In addition, the flowmeter is self-contained with all required accessories including vapor eliminator, strainer and differential valve.

The LPM-150 can be ordered with registration calibrated in U.S. gallons or liters, and is completely compatible with Neptune® 1½" flowmeters; both in external dimensions and its internal parts.

Primary Features

At the heart of the model LPM-150 flowmeter is the superior Liqua-Tech measuring chamber. It features a hard-coated piston with special dense metal oxide finish and hardened steel bearing shaft, field proven in thousands of installations.

The LPM-150 can be equipped with Veeder-Root printing or non-printing registers, for established reliability and lowest operating torque. The meter is also available configured with gear plate, star-driver, or spindle only for adaptation to third-party electronic registration units. The exclusive Liqua-Tech register gear plate adapter offers Neptune style change gears for ease of calibration.

The Liqua-Tech Difference

For over 15 years, Liqua-Tech Corporation has been an internationally recognized leader in the design and manufacture of top-quality LP-gas and NH3 flow meters and replacement parts.

Liqua-Tech currently produces complete ¾", 1" and 2" meters and ¾" through 2" replacement parts. 100% inspection on all metering components ensures that every product manufactured by Liqua-Tech Corporation conforms to exact tolerances

Specifications

Rate of Flow: 12 to 60 gpm (45 to 227 lpm) maximum.

Working Pressure: 350 psi (24 bar) maximum (24.6 Kg/cm²).

Connections: 1½" FPT on inlet check valve and differential pressure valve. Vapor eliminator and differential valve are flanged to flowmeter for easy installation. Standard configuration has inlet at left and outlet to right.

Materials

Housings Ductile Iron
O-rings & seals Buna-N

Register: Veeder-Root model 789002 (printing) or model 788700 (non-printing), with special Liqua-Tech VRA-Series gear plate adapter.

Units of Measure: Calibration is in U.S. gallons or liters.

Register

Reset Capacity 9,999.9 gallons, 9,999.9 liters.

Totalizer Capacity 9,999,999.9 gallons, 99,999,999 liters.

Operating Temperature: -10° F to 125° F (-23° C to 52° C).

Shipping Weight:

Without register or gear plate ??? lbs. (?? kg.)

With gearplate and printing register ??? lbs. (?? Kg.)

Neptune® is a registered trademark of Actaris Meter Systems. Liqua-Tech is an unaffiliated manufacturer of replacement parts for Neptune flowmeters.



LPM-150

1 1/2" LP-Gas Flowmeter

Standard Configurations - Non-Temperature Compensated

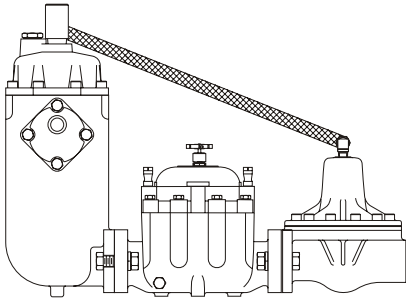

Without register or gear plate.

Part Number	Units of Measure
L090041-040	Gallons
L090041-050	Liters

Without register. Includes gear plate.

Part Number	Units of Measure
L090041-051	Gallons
L090041-053	Liters

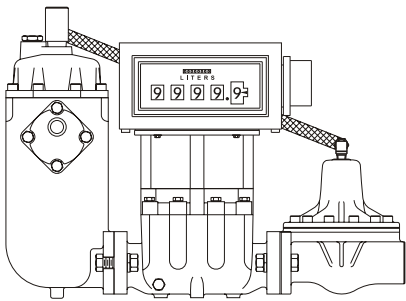
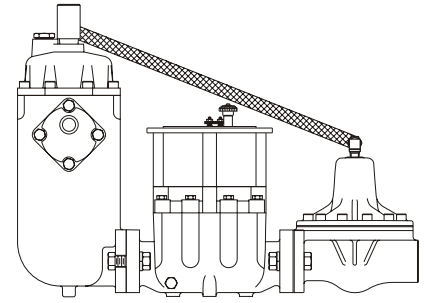

With Veeder-Root non-printing register.

Part Number	Units of Measure
L090041-101	Gallons
L090041-103	Liters

With Veeder-Root printing register.

Part Number	Units of Measure
L090041-102	Gallons
L090041-104	Liters

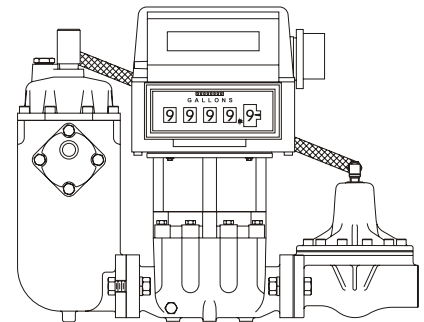

Replacement Parts

Ref.	Description	Part Number
1	Veeder-Root register, non-printing, US gallons	L788700-036
	Veeder-Root register, non-printing, liters	L788700-703
	Veeder-Root register, printing, US gallons	L789002-705
	Veeder-Root register, printing, liters	L789002-010
2	Screw, 3/8-16 x 1", socket head	L008325-014
	Screw, 3/8-16 x 1", socket head, drilled	L008325-015
3	Lockwasher, 3/8", high collar, steel	L100440-002
4	Lockwasher, 1/4", star	L100123-100
5	Screw, 1/4-28 x 5/8", hex head	L100061-100
	Screw, 1/4-28 x 5/8", hex head, drilled	L100061-011
6	Adapter plate, for Veeder-Root register, ATC	L886205-001
7	Stud, register mounting, S.S.	L084435-000
8	Set screw, 8-32 x 5/16"	L088796-000
9	Star driver, with setscrew	L082976-001
10	Screw, 7/16" NC x 1 1/4", hex head	L040237-004
	Screw, 7/16" NC x 1 1/4", hex head, drilled	L040237-005
11	Lockwasher, 7/16", steel	L041012-002
12	Cover, main case, non-ATC	L083479-701
13	Adapter, gear train, non-swivel	L085006-000
14	Gear train, 1 1/2", 9.375 ratio, LPG, 1 USG	L084981-000
	Gear train, 1 1/2", 25.4184 ratio, LPG, 1 liter,	L083280-052
15	Nut, stuffing box, complete w/bushing	L083536-000
16	Clamp nut, gear train, LPG	L000034-000
	Clamp nut, gear train, NH ₃	L000034-004
17	U-cup seal, gear train, Buna-N	L100025-002
18	Expander, U-cup	L083539-000
19	Spring, stuffing box	L083540-000
20	O-ring, gear train, Buna-N	L100138-003
21	Measuring chamber, 1 1/2", LPG	L083271-101
22	Gasket, main case	L004862-008
23	Housing, main case	L084978-702

Ref.	Description	Part Number
24	Gasket, flange	L082060-000
25	Plug, drain	L100075-003
26	Bolt, square head, 5/8-11 x 2 1/4"	L050223-002
27	Lockwasher, 5/8", steel	L041150-000
28	Nut, 5/8-11, hex	L041226-000
29	Vapor eliminator, complete, w/strainer and inlet check (see separate exploded parts view)	L084982-701
30	Hose, connecting, with fittings	L084823-010
31	Differential valve, complete	L084985-701
32	Fitting, elbow, 3/8" NPT x 3/8" SAE	L084825-001
33	Cover, differential valve	L083766-701
34	Screw, 3/8-16 x 1", hex head	L100067-027
	Screw, 3/8-16 x 1", hex head, drilled	L100068-027
	Screw, 3/8-16 x 1" socket head	L008325-014
	Screw, 3/8-16 x 1" socket head, drilled	L008325-015
35	Lockwasher, 3/8", steel (for hex head)	L100440-001
	Lockwasher, 3/8", steel, high collar (for socket head)	L100440-002
36	Spring	L083775-000
37	Diaphragm, complete	L083946-006
38	Diaphragm screw	L083774-002
39	Lock washer, plated, 7/16"	L041012-002
40	Spring retainer	L083773-000
41	Diaphragm retainer	L083772-002
42	Diaphragm	L083771-002
43	O-ring	L100139-001
44	Valve stem assembly, (bronze)	L083768-002
45	Body, differential valve, 1 1/2"	L084986-701
46	Seal pin, measuring chamber, w/slot, LPG	L042792-000
47	Control roller, measuring chamber, LPG (LTC)	L043275-010
48	Diaphragm, 1 1/2" measuring chamber, LPG	L083277-000

LPM-150

Replacement Parts

Meter - Complete

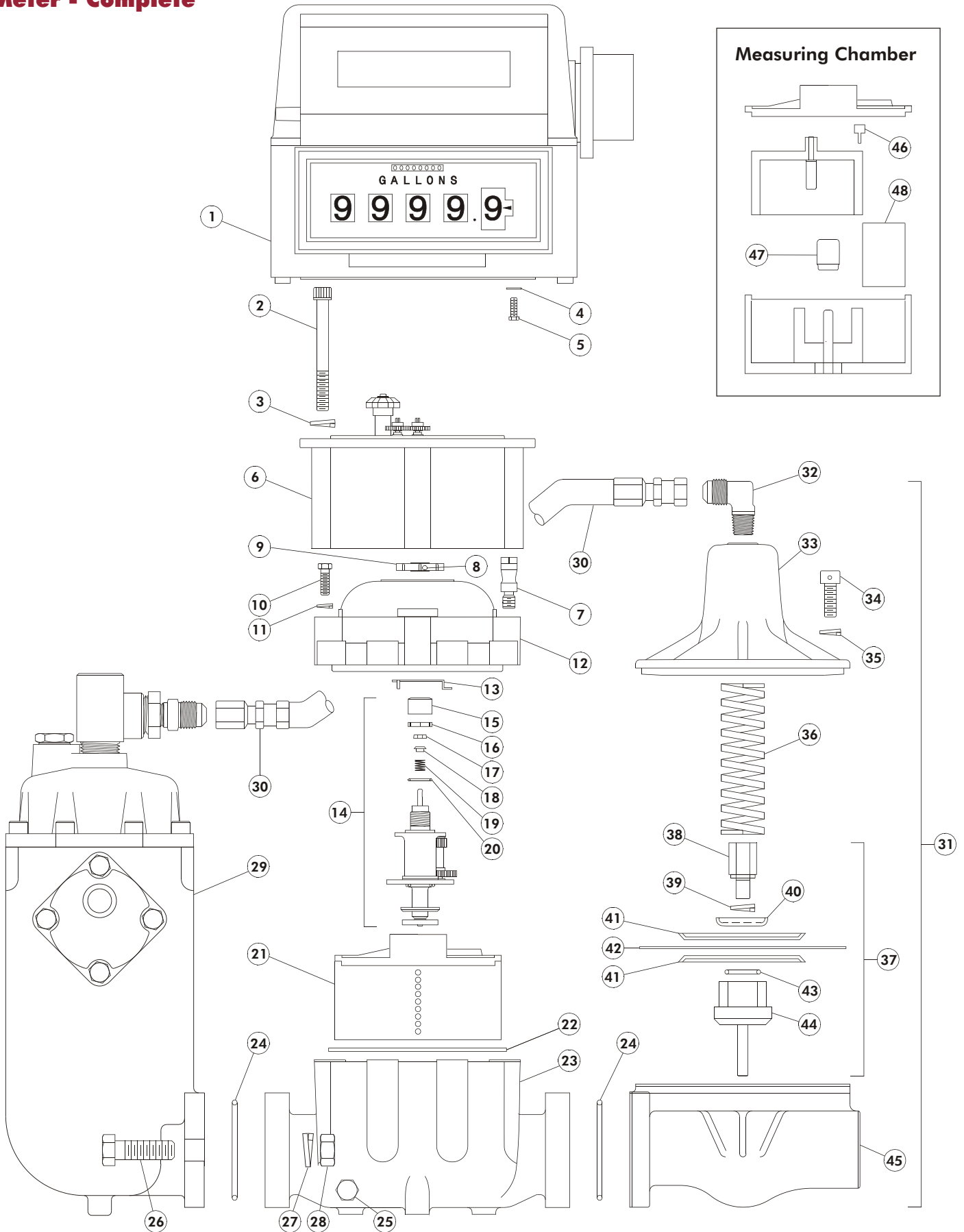

LPM-150

Replacement Parts

Vapor Eliminator & Strainer

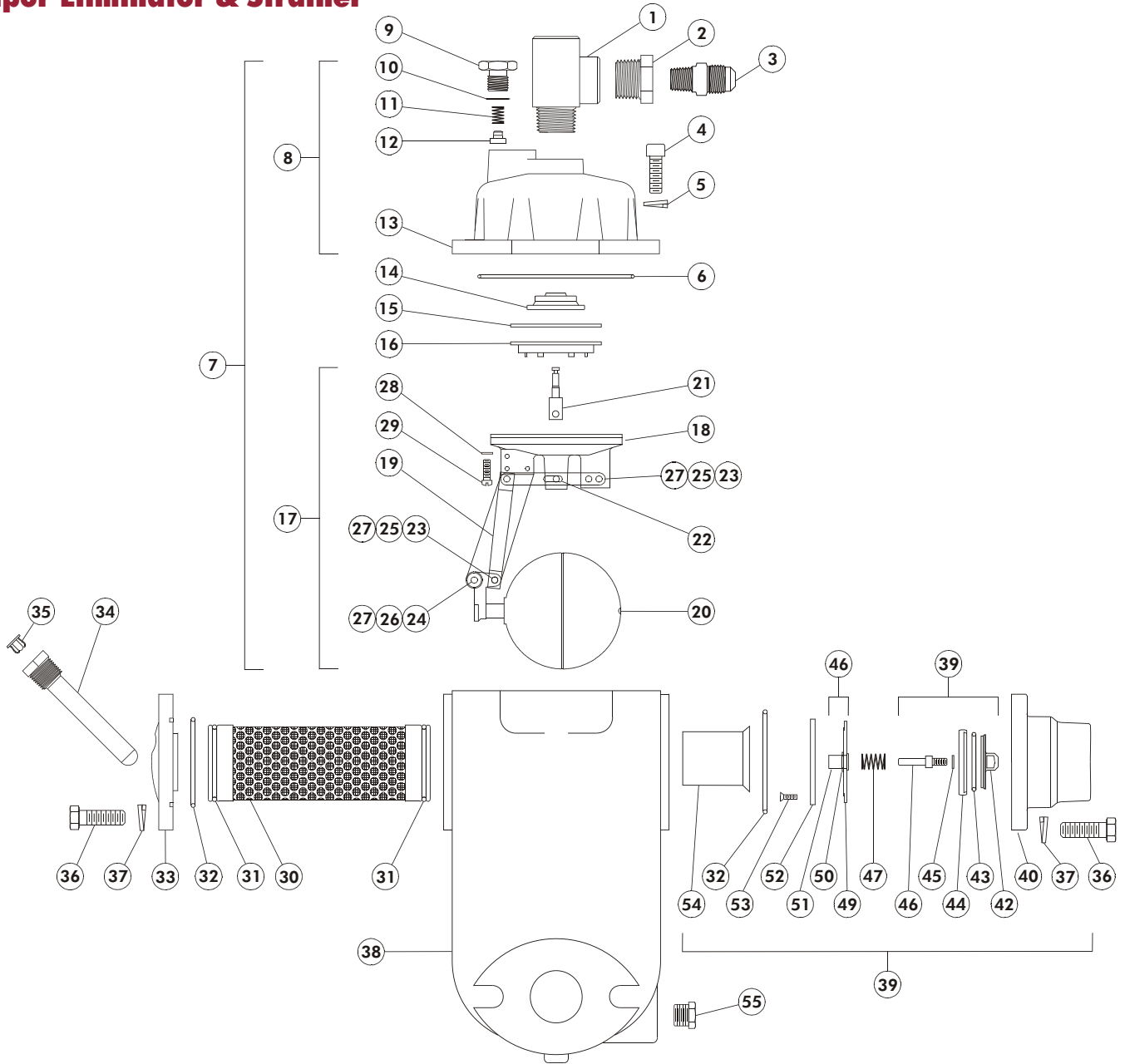

Ref.	Description	Part Number
1	Street tee, 3/4", high pressure	L084826-101
2	Bushing, 3/4" x 1/4"	L084826-050
3	Fitting, straight, 3/8" male flare	L084826-000
4	Screw, 3/8-16 x 1" socket head	L008325-014
5	Lock washer, 3/8" steel, high collar	L100440-002
6	O-ring, vapor release cover	L100139-022
7	Mounting cover w/float valve	L083481-701
8	Cover assembly, vapor release	L100148-001
9	Screw, pressure relief (w/tag)	L100333-001
10	O-ring, pressure relief screw	L100138-006
11	Spring, compression	L100024-003
12	Valve assembly, bypass	L100237-001
13	Cover, vapor release	L100147-901
14	Main valve, complete	L089274-000
15	Piston seal	L083179-000
16	Sleeve, valve	L082446-005
17	Lower valve housing, complete	L086797-001
18	Valve housing with extensions	L082455-000
19	Link assembly	L100034-001
20	Float complete	L082476-001

Ref.	Description	Part Number
21	Valve stem	L083127-001
22	Pin, valve stem	L042941-000
23	Pin, short (.68")	L082633-000
24	Pin, float to lever, long (1.37")	L040820-003
25	Washer, pin (short)	L041989-000
26	Washer, float lever pin (long)	L040491-000
27	Cotter pin, 1/16" x 1/2", 304 SS	L041402-000
28	Lock washer, #10, steel	L041211-000
29	Screw, 10-32 x 5/8", filister	L041221-002
30	Strainer, new style, 80 mesh	L101433-704
	Strainer, new style, 60 mesh	L101433-703
	Strainer, new style, 40 mesh	L101433-702
	Strainer, new style, 16 mesh	L101433-701
31	O-ring, Buna-N	L100139-032
32	Gasket, o-ring	L100161-001
33	Strainer cover	L083485-702
34	Thermowell	L086666-702
35	Cover, thermowell	L083732-000
36	Screw, 3/8"-16 x 1", hex head	L100067-027
	Screw, 3/8"-16 x 1", hex head, drilled	L100068-027

Ref.	Description	Part Number
37	Lock washer, 3/8" steel	L100440-001
38	Body, vapor release and strainer	L083495-701
39	Inlet check valve, soft seat, 1 1/2"	L084983-704
40	Flange, inlet, 1 1/2"	L084984-005
41	Inlet disk assembly	L100895-001
42	Retainer, disk	L100897-001
43	O-ring, soft seat	L100146-003
44	Holder, disk seat	L100423-002
45	Lockwasher, 1/4", steel	L100121-009
46	Shaft, valve stem	L100896-001
47	Spring	L100892-000
48	Bearing support assembly	L100895-050
49	Strap, center bearing support	L083493-003
50	Retaining ring, 1/2"	L086071-000
51	Bearing	L100899-001
52	Collar ring, retaining	L083441-000
53	Screw, 6-32 x 1/2", flathead	L083442-000
54	Tubing, strainer support	L085965-001
55	Plug plug, 1/2"	L100076-003